

# QUICK START GUIDE

## CB-950 DATA BUOY PLATFORM



**Figure 1:** CB-950 Data Buoy Overview

### Overview

The NexSens CB-950 data buoy platform is constructed with a closed cell, cross-linked polyethylene foam hull with polyurea coating that provides 950 lb buoyancy. The buoy has a corrosion resistant, stainless steel internal frame with topside lifting eyes and subsurface mooring eyes for connection of single-point and multi-point mooring systems.

An integrated data well located within the buoy hull accommodates batteries and electronics. The data well lid is available as a NexSens iSIC-CB data logger assembly or as a standard lid with pass-through fittings for use with user-supplied electronics. Internal batteries are recharged by (3) 30-Watt solar panels mounted on the buoy tower, which also supports an optional LED beacon, radar reflector, and RTU-R/C/I radio, cellular or Iridium satellite telemetry module.



### What's Included

- (1) Buoy hull with data well, 950 lb buoyancy
- (1) Buoy tower
- (3) 40W Solar panels
- (1) Data well lid (*iSIC-CB* or pass-through)
- (3) Top-side lifting eyes
- (3) Bottom-side mooring eyes
- (1) Instrument cage, large

### Common Accessories

- *iSIC-CB* data logger enclosure
- *RTU-R/C/I* telemetry module
- *CB-A05-2* battery harness/regulator assembly, (2) x 28 A-Hr batteries
- *CB-A05-3* battery harness/regulator assembly, (3) x 28 A-Hr batteries
- *M650H-Y* LED beacon
- *RA-4180-1* mini radar reflector
- *916M* 6" sensor deployment pipes
- *CB-PW-AC-60W* battery charger

### Assembly

The main components of the CB-950 data buoy platform are assembled at the time of shipment. Installation of accessories may be required. Quick instructions are provided in this guide. Visit the online Knowledge Base for more information (see *Additional Information* section).

### Instrument Cage

The instrument cage is connected to the buoy using a *CB-CCA* cage clamp accessory. Reference the instructions provided with the clamp for installation. Welding the cage and/or installing additional security straps is also recommended for use in rough water.

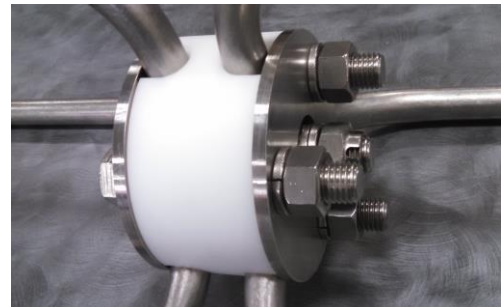

**Figure 2:** Cage with CB-CCA Clamp

# QUICK START GUIDE

## CB-950 DATA BUOY PLATFORM

### **Solar Tower**

The top plate of the solar tower has hole patterns designed for mounting of an *M650* beacon, *RTU-R/C/I* telemetry module, *RA-4180-1* mini radar reflector, and/or a weather sensor mount. These devices are typically mounted on the tower in the factory prior to shipment. Make any changes or additions prior to installation of the tower onto the buoy.

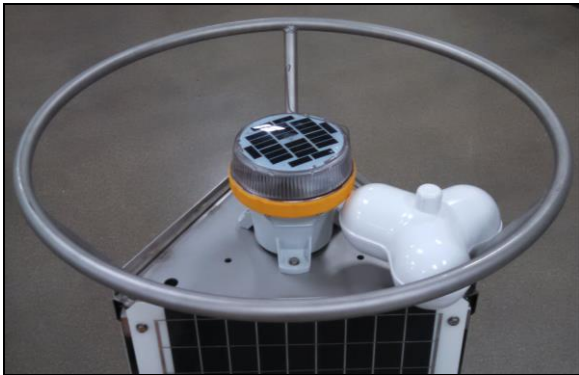

**Figure 3:** Tower with Beacon and Radar Reflector

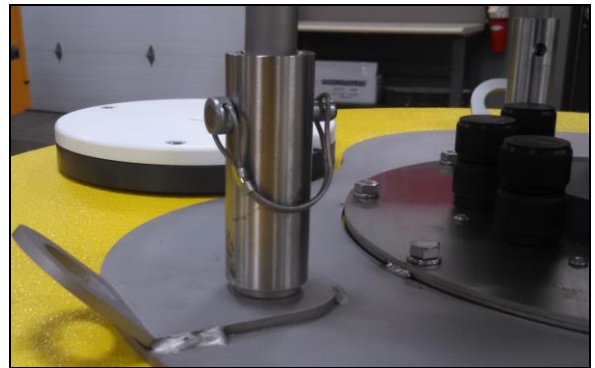

**Figure 4:** Tower with Beacon and RTU-C Module

When the tower is ready to be mounted, remove the locking pin from each of the three tower mounting hubs on top of the buoy hull. Place the tower legs into the hubs and secure the locking pins.



**Figure 5:** Locking Pin and Tower Mount Hub



**Figure 6:** Installed Tower

### **Deployment Pipe**

The bottom of the buoy hull includes (3) 6" female threaded couplings for connection of NexSens 916M deployment pipe assemblies or other PVC fittings. To use these ports, simply thread each deployment pipe securely into one of the available couplings.

Instruments deployed in 916M pipes can easily be accessed for calibration and maintenance by removing the port cover plate from the top of the buoy hull. Use a 5/16" Allen/hex key to remove the set of screws on the cover plate.

# QUICK START GUIDE

## CB-950 DATA BUOY PLATFORM

### Wiring & Device Connections

#### NexSens iSIC-CB Data Well Lid

For systems using NexSens electronics for data acquisition and telemetry, the iSIC data logger is housed in an iSIC-CB enclosure that provides a watertight seal over the data well. The bottom of the iSIC-CB has a power plug that connects to a CB-A05-2/3 battery/solar regulator assembly. The top of the iSIC-CB enclosure has a series of UW ports for connection of solar panels, sensors, communication devices, and external power supplies to the iSIC.

The available ports and functions are:

- (5) *SENSOR (P0/P1/P2)*: NexSens sensorBUS architecture includes wiring for SDI-12, RS-232 and RS-485 devices. For compatibility, sensors must have a factory-installed UW plug connector. The sensor ports are wired as follows:
  - (2) *P0*: 12V full power, shared RS-232 port.
  - (2) *P1*: 12V switch power, shared RS-232 port.
  - (1) *P2*: 12V switch power, unique RS-232 port.
- (1) *COM*: Communications port for iSIC data logger configuration and data acquisition through *UW-USB-232P-NP* cable or *RTU-R/C/I* radio, cellular, or Iridium satellite telemetry module.
- (1) *SOLAR*: 6-pin input for solar panel to apply system power and charge internal battery. Solar cable or a specialized UW plug with jumper (P/N *UW-JUMPER*) must be connected to SOLAR port to power the iSIC.
- (1) *VENT*: Gortex vent for relief of outgassing pressure during recharge of batteries located in the data well. In heavy wave conditions, this vent can be plumbed with tubing to the top of the tower.

The sharing of RS-232 ports on P0 and P1 means that only one non-addressable device can be connected at a time. For example, two devices with RS-232 NMEA0183 output will interfere with

each other if both are connected to P0. RS-485 and SDI-12 ports are shared throughout the bus.



Figure 7: iSIC-CB Enclosure

Devices with analog outputs (e.g. 4-20 mA, 0-2.5 VDC) may be connected to the iSIC-CB through a *mV-RS485* adapter, which converts the analog signal to RS-485 Modbus. The *mV-RS485* adapter must be programmed for the specific sensor connected. See the instructions provided with the adapter for more information.



Figure 8: mV-RS485 Adapter

# QUICK START GUIDE

## CB-950 DATA BUOY PLATFORM

Table 1 shows the sensorBUS signal for each pin on the UW receptacle ports of the iSIC-CB. The pins are numbered based on the diagram in Figure 9 (plug pins are 1-4, socket pins are 5-8). The table also lists the corresponding wire color for a UW plug to flying lead cable connected to a port (see Figure 10).

The system battery voltage can be checked externally by placing the leads of a voltmeter on pins 4 (red) and 7 (black) of a *P0* or *COM* port.

**Table 1:** UW Receptacle sensorBUS Wiring

UW Receptacle Pin	Wire Color	sensorBUS Signal
1	Green	RS-485 A
2	Blue	RS-485 B
3	Brown	SDI-12
4	Red	12V Power
5	White	5V Power
6	Yellow	RS-232 Rx
7	Black	GND
8	Orange	RS-232 Tx

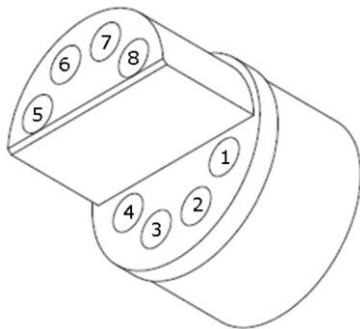

**Figure 9:** UW Connector Pinout



**Figure 10:** UW Plug to Flying Lead Cable

### **Pass-Through Data Well Lid**

For applications with user-supplied sensors, data loggers, telemetry modules and/or batteries, the CB-950 data buoy is provided with a data well lid with a set of plugs and pass-through fittings for securing user-supplied instrument cables. The lid includes the following ports:

- (6) *PASS-THROUGH*: Blank UW receptacles supplied with a set of plugs for sealing unused ports and a set of fittings for securing instrument cables going into the data well.
- (1) *SOLAR*: 6-pin port for connection of solar panel assembly. Includes connector inside data well for use with optional CB-A05-2/3 battery/solar regulator harness. For use with user-supplied battery/regulator systems, see *Solar Power Wiring*.
- (1) *VENT*: Gortex vent for relief of outgassing pressure during recharge of batteries located in the data well.

*Tighten the fittings securely around cables routed into the data well to maintain the watertight seal. Plug all ports that are not used.*

# QUICK START GUIDE

## CB-950 DATA BUOY PLATFORM

For a more robust connection at the data well plate, the pass-through ports may be fitted with *UW-BULK* bulkhead receptacle connectors. The *UW-BULK* assembly has the same pinout as iSIC-CB sensor ports (see Table 1), but the cable terminates in flying leads for integration with a user-supplied data logger. The device connected must have a factory-installed UW connector.



Figure 11: UW-Bulkhead Connector Assembly

### Solar Power Wiring

Figure 12 shows a schematic drawing for the wiring of the CB-950 power supply. The system includes (3) 30-watt solar panels that connect through the *SOLAR* port on the data well plate to the *CB-A05-2/3* or user-supplied battery/solar regulator harness. A wire lead is provided to supply 12V DC power to electronics inside the data well (red = +12V, black = GND).

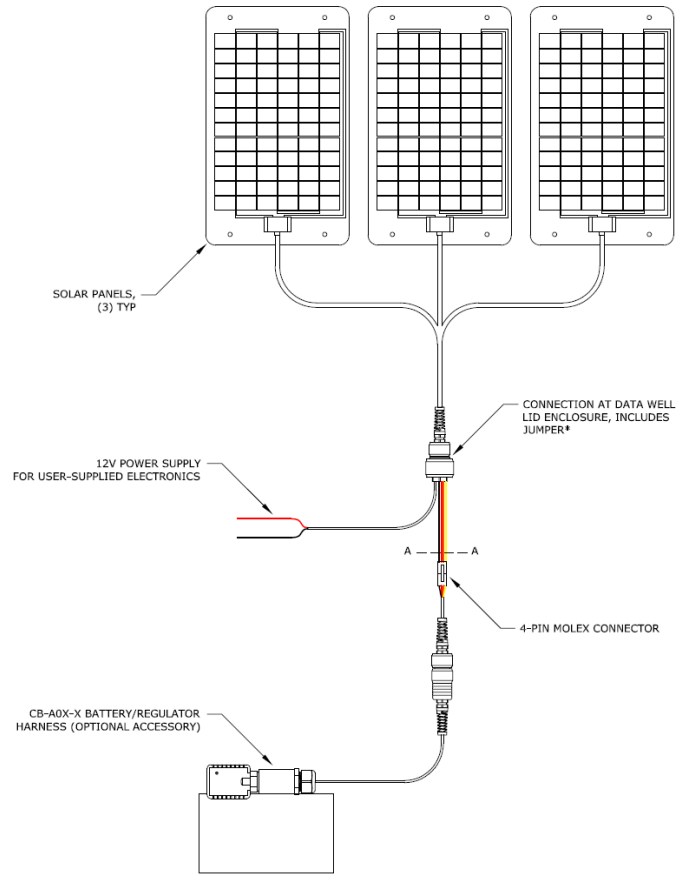

Figure 12: Wiring Schematic

**\*NOTE:** The 12V power supply leads for user supplied electronics will only supply power when the solar panel is plugged into the SOLAR port on the data well lid, even if a battery is connected inside the data well. To supply battery power without plugging in the solar panel, a special UW plug with internal jumper is available (P/N UW-JUMPER).

For systems with user-supplied battery and solar regulator, the battery and regulator can be connected through the 4-pin Molex connector or by cutting the wires at section A-A in Figure 12 and splicing the connections. In these situations, reference the signals listed in Table 2.

# QUICK START GUIDE

## CB-950 DATA BUOY PLATFORM

**Table 2:** Wiring for user-supplied battery/regulator

Signal	Wire Color
+12V	Red
GND	Black
Solar input	Yellow
Charge output	Orange

### Ballast Weight and Stability

To prevent overturning of a CB-950 buoy system and to ensure that it is stable in the water, a minimum ballast weight of 125 lbs. is needed for calm deployment locations and more in rough waters. The center of gravity of the buoy is somewhere near the water surface without instruments connected. Any weight added above the water surface must be appropriately counterbalanced by adding ballast weight below the surface.

The larger the distance from the location of added weight to the center of gravity, the greater the effect on the stability of the buoy will be. For example, if a weather sensor is mounted 36" above the water surface, it will cause more instability than if it were mounted 24" above the surface and, as a result, would require more subsurface ballast weight to counterbalance the buoy. Conversely, a ballast weight added further below the surface will provide a greater stabilizing effect than the same size weight mounted closer to the surface.

An instrument cage mounted to the buoy frame helps to stabilize the buoy and provides a deeper location for mounting additional weight. For single-point mooring configurations, mooring chain and lines connected to the bottom of the cage may provide adequate ballast. For multi-point configurations, the mooring hardware does not contribute to the ballast weight.

Before deployment of a CB-950 system, some experimentation may be required to properly balance the buoy. If needed, add 1/2" chain (~2.3lb/ft) or other weight to the bottom of the

cage. Figure 13 shows an example of a buoy system with a short section of chain added.

*The buoy data well is not rated for submersion, so proper ballast weight is critical to ensure that the buoy does not overturn, including when the buoy is subjected to additional loading (e.g. high wind/waves, periodic snow/ice loads, etc.).*

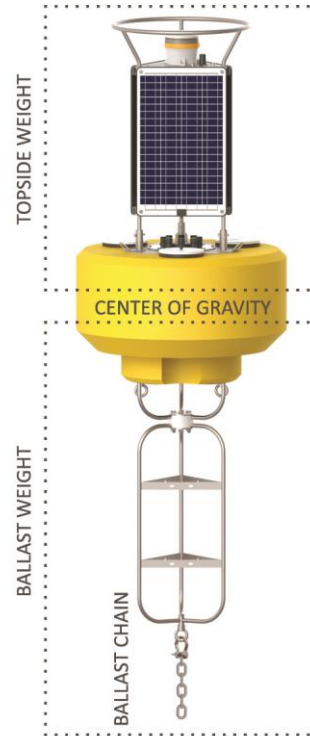

**Figure 13:** CB-950 Data Buoy with Ballast Chain

### Saltwater Deployment

Sacrificial zinc anodes should be used whenever a buoy is deployed in a saltwater environment to prevent corrosion. These zinc anodes must be inspected and replaced as needed.

# QUICK START GUIDE

## CB-950 DATA BUOY PLATFORM

### Mooring Configurations

*This section contains only general information on the available mooring options for CB-950 data buoys. To develop an effective mooring strategy, a variety of application-specific criteria (water level fluctuations, currents and wave action, debris loads, etc.) must be thoroughly reviewed prior to deployment. NexSens does not endorse any particular mooring strategy for any specific application.*

#### Single-Point Mooring

Single-point moorings are used in calm waters when monitoring sensors are attached to the instrument cage or housed in deployment pipes. The sensors are thus protected and less vulnerable to damage caused by subsurface debris, high currents, and entanglement from anchor lines.

In a single-point configuration, a stainless steel mooring line connects the buoy directly to a bottom chain and anchor. At normal pool/stage, the mooring line should be taut, with most of the bottom chain resting on the floor of the water body. As the water level increases and the buoy rises, the bottom chain is lifted from the floor.

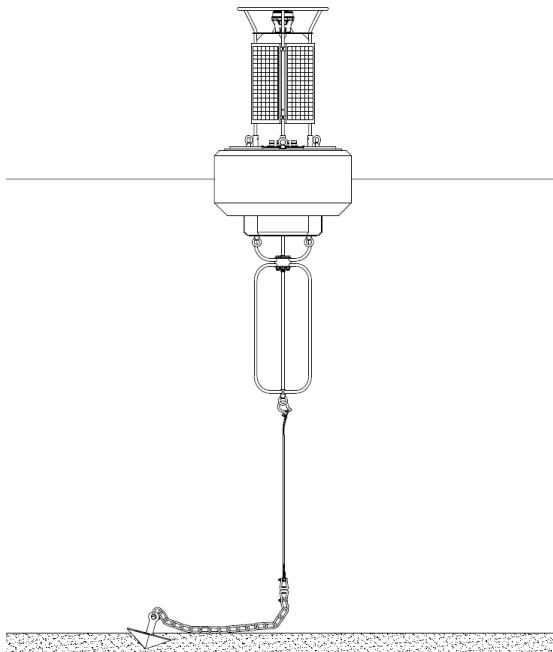

Figure 14: Typical Single-Point Mooring Configuration

#### Two-Point Mooring

Two-point moorings are commonly used when monitoring sensors are deployed in the water column below the buoy. In this setup, the mooring lines are pulled taut away from the buoy, freeing the water column for a suspended sensor line.

In most two-point configurations, mooring lines connect the data buoy to small marine marker floats, often located on the water surface. These marker floats are shackled to another mooring line that runs to the floor and connects to a bottom chain and anchor assembly. Additional subsurface marker floats may also be used in some applications. As in single-point systems, the bottom chain prevents buoy submersion as the water level fluctuates.

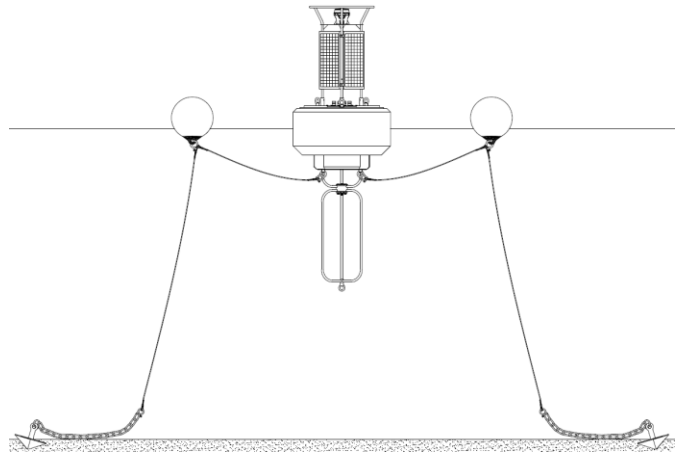

Figure 15: Typical Two-Point Mooring Configuration

# QUICK START GUIDE

## CB-950 DATA BUOY PLATFORM

### Safe Deployment

*Personnel safety is the number one priority when deploying a data buoy. Use of proper equipment (work boat, lifting rig, gloves, safety footwear, etc.) is essential to safely deploy any buoy system. Buoy systems are heavy and personnel can quickly become entangled with mooring lines and anchors. Safety and flotation gear should be worn at all times when working on or near the water.*

*Remember to perform a complete system test on shore prior to deployment. Learning the nuances of the system is much better handled on shore or in a lab rather than in the field.*

### Specifications

- **Hull Dimensions:** 42" (106.70cm) outside diameter; 26" (66.04cm) tall
- **Tower Dimensions:** 45" (114.30cm) tall, 7/8" tubular
- **Data Well Dimensions:** 10.3" (26.16cm) inside diameter; 25.5" (64.77cm) tall
- **Weight:** 285 lbs. (129.27 kg)
- **Buoyancy:** 950 lbs. (430.91 kg)
- **Hull Material:** Cross-linked polyethylene foam with polyurea coating & stainless steel deck
- **Tower/Hardware Material:** 304 stainless steel
- **Other Material:** Galvanized ballast chain
- **Mooring Attachments:** 1- or 2-point, 3/4" eye nut
- **Solar Power:** (3) 40-watt, 12VDC solar panels

### Additional Information

Additional information and complete instructions for the CB-950 data buoy platforms are available in the NexSens online Knowledge Base:

<http://www.nexsens.com/knowledge-base>

<http://www.nexsens.com/category/knowledge-base/data-buoys/cb-950-buoy>

