

# CB-40 DATA BUOY

## QUICK START GUIDE

**IMPORTANT - BEFORE FIELD DEPLOYMENT:** Completely configure and test the internal logging of your sensor. Confirm that the batteries will provide adequate power for the duration of the deployment. Ensure that all external sensor ports and battery compartments have a watertight seal.



Figure 1: NexSens CB-40 Data Buoy

### Overview

The CB-40 data buoy is designed for deploying water quality sondes and other instruments that integrate power and data logging. An integrated 4" diameter instrument pipe securely houses the instrument. Compatible instruments include YSI 6-Series and EXO sondes, Hydrolab Series 5 & HL sondes, Eureka Manta sondes and In-Situ Aqua TROLL instruments. The CB-40 supports 1, 2, and 3-point mooring via a bottom bow shackle and three eyenuts.

### What's Included?

- (1) Buoy hull
- (3) Top-side lifting eyes
- (3) Bottom-side mooring eyes
- (1) Integrated 4" diameter instrument pipe

### Important Specifications

*Instrument pipe dimensions:* 3.87" (9.83cm) inside diameter; 48" (121.92cm) tall.

*Weight:* 38 lbs. (17.24 kg) no payload; ~45 lbs. (20.41 kg) with sonde and solar marine light.

*Buoyancy:* 40 lbs. (18.14 kg)

### Instrument Installation

- 1 Using a 3/16" allen wrench, remove the four bolts from the white top plate.

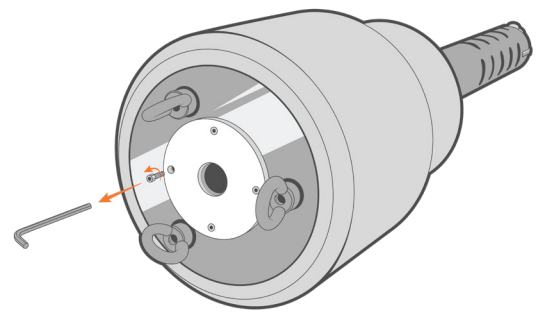

Figure 2: Remove the top white plate.

- 2 Insert the sensor into the stainless steel buoy well.
  - a. Ensure to remove any calibration cups and install any probe guard accessories.

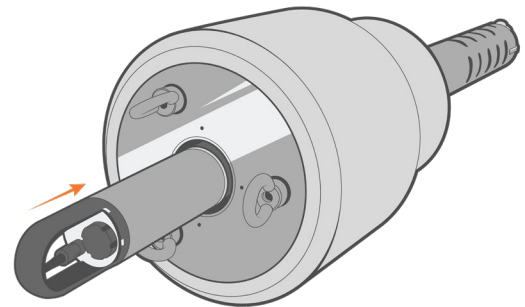

Figure 3: Insert the sensor with the probes facing towards the bottom of the instrument pipe.

- 3 Re-install the top plate.
  - a. Place a zip tie through the bolt hole of the bottom bow shackle to ensure the bolt does not loosen during deployment.

## Mooring Configurations

To develop an effective mooring strategy, a variety of application-specific criteria (water level fluctuations, currents and wave action, debris loads, etc.) must be thoroughly reviewed prior to deployment. NexSens does not endorse any particular mooring strategy for any specific application.

- a. For more information on mooring configurations, follow the link provided:

- [nexsens.com/mooringdb](https://nexsens.com/mooringdb)

## Safe Deployment

*Warning:* Always follow safe marine and boating practices. Heavy anchors, ballast weights, and chain require careful maneuvering. Small boats with limited lifting equipment and boat clutter can be unsafe. Care must be taken during deployment to maintain a clean and safe environment.

## Saltwater Deployment

Sacrificial zinc anodes should be used whenever a buoy is deployed in a saltwater environment to prevent corrosion. These zinc anodes must be inspected and replaced as needed.

## Ballast Weight & Stability

Typically, no additional ballast is necessary as the instrument pipe provides adequate weight. However, if needed, a 1/2" chain (~2.3 lb/ft) or other weight may be added to the bottom of the instrument pipe.

- a. For more information regarding top-side and ballast weight, follow the link provided:

- [nexsens.com/dbbwstab](https://nexsens.com/dbbwstab)

## CB-40 Buoyancy

Due to the weight of the instrument pipe, the center of gravity of the buoy is just below the water's surface. It is recommended to use galvanized chain for ballast; however, the exact weight is dependent upon the conditions at the deployment location.

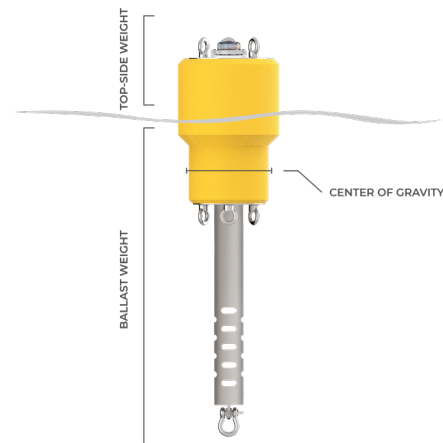

Figure 4: CB-40 buoyancy diagram.

For additional information, please reference the CB-40 Resource Library on the NexSens Knowledge Base.

[nexsens.com/cb40kb](https://nexsens.com/cb40kb)