

CB-25 DATA BUOY

QUICK START GUIDE



Figure 1: NexSens CB-25 Data Buoy

Overview

The CB-25 data buoy is constructed of an inner core of cross-linked polyethylene foam with a polyurea coating that provides 25 lb. buoyancy. Stainless steel plates on the top and bottom of the buoy provide topside lifting handles and subsurface mooring eyes for drifting, tethering, or mooring applications. The center hole accommodates the X2-SDLMC data logger, which includes internal batteries that are recharged by (3) 4-watt solar panels mounted on the top plate.

What's Included?

- (1) Buoy hull, 25 lb. buoyancy
- (1) Buoy tower
- (3) 4-W solar panels
- (3) 1.5" pass-through sensor pipes
- (3) Top-side lifting handles
- (3) Bottom-side mooring eyes
- (1) 2ft. Bottom chain
- (1) Instrument cage (Optional)

Important Specifications

Buoyancy: 25 lbs. (11.34 kg)

Weight: 30 lbs. (13.61 kg)

Center Hole Dimensions: 5.5" (13.97 cm) inside diameter;
11" (27.94 cm) tall

Instrument Cage Installation (Optional)

- 1 Use a Philips head screwdriver to remove the top white plate from the solar tower.

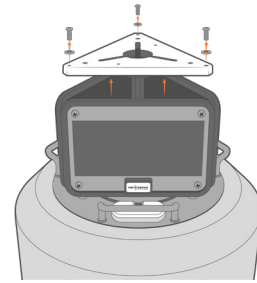

Figure 2: Top plate removal.

- 2 Use a Philips head screwdriver to remove the internal screws on the solar tower.

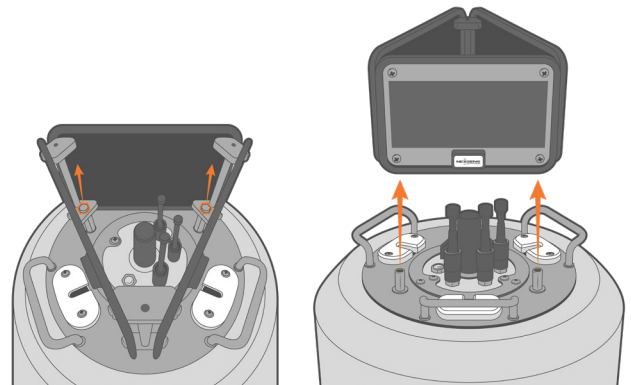

Figure 3: Solar tower removal.

- 3 Use a Philips head screwdriver to remove the outside screws holding down the X2-SDLMC.

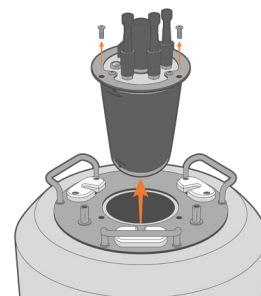

Figure 4: X2-SDLMC removal.

- 4 Use the provided bolt, lock washer and castle nut to attach the cage to the buoy frame.
 - a. Insert the bolt through the center hole within the buoy hull.
 - b. Place the black ballast washer between the cage and the bottom buoy plate.

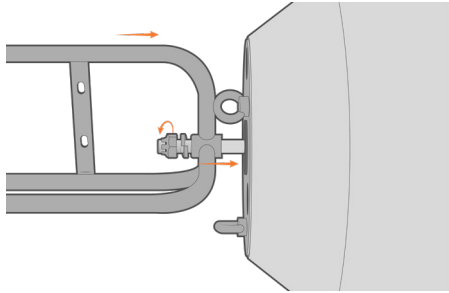

Figure 5: Bolt installation and cage connection.

- 5 Tighten firmly with a pair of 1-1/8" wrenches.
 - a. Ensure to flatten the lock washer and align the bolt hole with a notch on the castle nut.
- 6 Place the cotter pin through the bolt hole and bend the long leg of the pin.

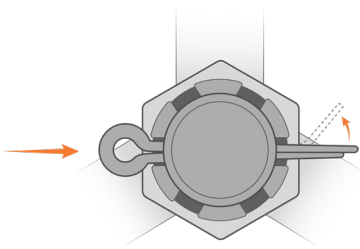

Figure 6: Cotter pin installation. Bent pin for security.

Mooring Configurations

To develop an effective mooring strategy, a variety of application-specific criteria (water level fluctuations, currents and wave action, debris loads, etc.) must be thoroughly reviewed prior to deployment. NexSens does not endorse any particular mooring strategy for any specific application.

- a. For more information on mooring configurations, follow the link provided:

• nexsens.com/mooringdb

Deployment

Warning: Always follow safe marine and boating practices. Heavy anchors, ballast weights, and chain require careful maneuvering. Small boats with limited lifting equipment and boat clutter can be unsafe. Care must be taken during deployment to maintain a clean and safe environment.

Sacrificial zinc anodes should be used whenever a buoy is deployed in a saltwater environment to prevent corrosion. These zinc anodes must be inspected and replaced as needed.

Ballast Weight & Stability

If a small NexSens cage (~10lbs.) is purchased, this will provide adequate ballast. **No mooring apparatus should be connected to the bottom of the cage.** Without a NexSens cage, galvanized chain can be utilized for ballast on the middle eye nut, keeping in mind the 25lbs. of buoyancy. The outside eye nuts should be utilized for tethering to another flotation device.

- a. For more information regarding top-side and ballast weight, follow the link provided:

• nexsens.com/dbbwstab

The buoy data well is not rated for submersion, so proper ballast weight is critical to ensure that the buoy does not overturn, including when the buoy is subjected to additional loading (e.g. high wind/waves, periodic snow/ice loads, etc.).

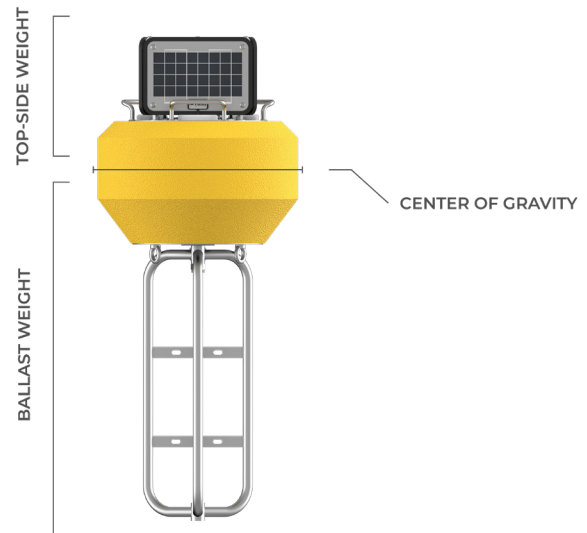

Figure 7: CB-25 buoyancy diagram.

For additional information, please reference the CB-25 Resource Library on the NexSens Knowledge Base.

nexsens.com/cb25kb