

A50 JUNCTION BOX

INSTALLATION INSTRUCTIONS



Figure 1: NexSens A50 Junction Box.

What's Included

A50 Junction Box hardware

- (2) Nickel-plated gland fittings w/ nuts
- (2) Mounting braces
- (4) 1/4-20 x 1-1/4" Pan head screws
- (4) 1/4" Flat washers
- (4) 1/4-20 nuts
- (4) 1/4-20 x 1/2" Flat head screws
- (2) Straps for 2" pipe
- (1) 12-Position terminal block for fork-style connections.

Gland Fitting Installation

Two gland fittings are pre-installed on the A50 junction box. If more are required, follow the subsequent steps.

- 1 Use a flathead screwdriver to remove the top plate on the A50 junction box.

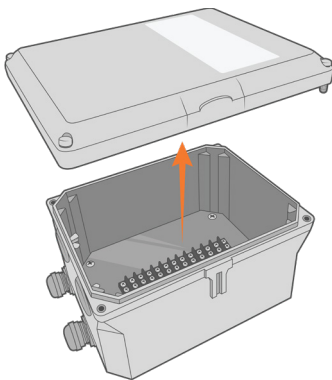

Figure 2: Remove top plate.

- 2 Remove one of the plug nuts.

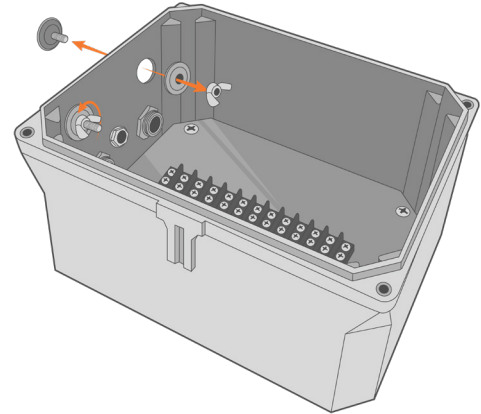

Figure 3: Plug nut removal.

- 3 Remove the nut on one of the gland fittings.
 - a. Insert the threaded portion into the opening.
 - b. Rotate the nut onto the threads and tighten using adjustable wrenches on both sides of the gland fitting.
 - c. Note: Ensure the white gasket on the outside is displaced evenly while tightened. Uneven distribution may allow for water intrusion.

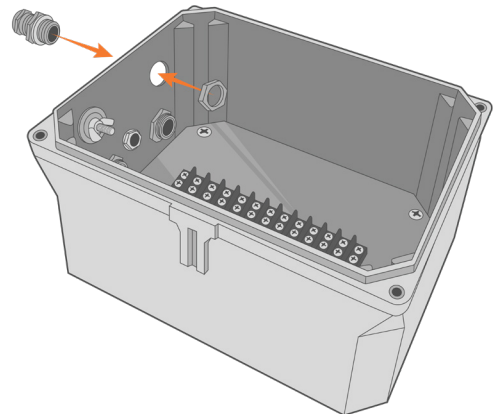

Figure 4: Gasket installation.

- 4 Route the cable through the gland fitting.
 - a. Hold the cable in position and tighten the gland fitting around the cable using an adjustable wrench.
 - b. Note: Ensure not to over-tighten and put stress on the cable.

Wiring into the A50 (Fork terminal example)

- ① Strip 1/4" of each flying lead wire.
 - a. Fold the conductor in half over itself.
- ② Slide on the fork terminal until the wire is visible through the hole.
 - a. Crimp using a hand held crimp tool.
 - b. Ensure to crimp enough to secure the wire. Pull on the wire to ensure a solid connection.
- ③ Loosen a screw on the terminal strip until enough room is available to insert the fork connector.
 - a. Slide the fork connector in place and tighten down the screw.
 - b. Note: A maximum of (2) fork terminals can be connected to each pin.

Junction Box Mounting

- ① Set the junction box on its face and align one of the included mounting braces with the top threaded inserts.
 - a. Secure the brace using (2) of the included flat-head screws.
 - b. Thoroughly tighten the screws using a flat head screwdriver.

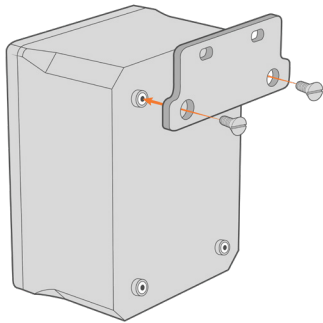

Figure 5: Install top brace.

- ② Attach the other mounting brace to the 2" NPT deployment pipe or MAST accessory using one of the included straps.
 - a. Place the included flat washer, lock washer, and nut on the Phillips head screws.
 - b. Evenly tighten the brace using a 1/2" socket on each nut.
 - Note: Be careful not to over-tighten the screws as it may cause the hardware to bend or break. The straps may not be fully flush with the braces.

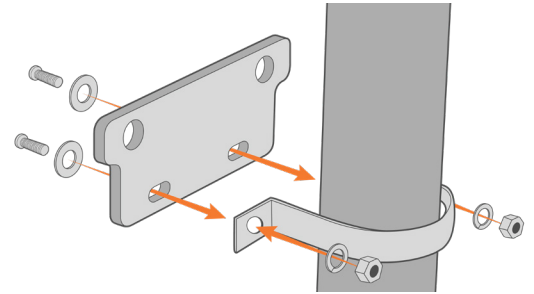

Figure 6: Install second brace on pipe mount.

- ③ Align the bottom threaded inserts of the junction box with the brace mounted on the pipe.
 - a. Secure the lower brace using the remaining flat head screws.
 - b. Run the remaining strap around the pipe and align with the top brace.
 - Secure it with the remaining Phillips-head screws, flat washer, lock washer, and nut. Evenly tighten the brace using a 1/2" socket. Ensure the brace does not bend.

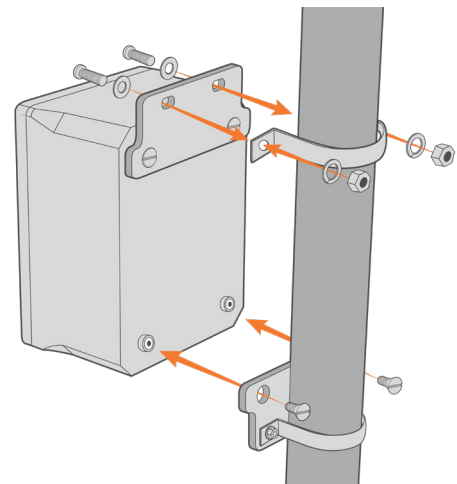

Figure 7: A50 junction box installed on pipe mount.