

Vaisala WXT520

Multi-Parameter
Weather Sensor

Sensor Interface Manual



Table of Contents

Overview	1
Connecting to an iSIC Data Logger	2
Installation	7
Mounting Weather Sensor	7
Wind Direction Alignment.....	8
Computer Interface	9

Revision: 03 **Revision Code:** 20A10

Overview

The WXT520 multi-parameter weather sensor simultaneously measures wind speed and direction, liquid precipitation, barometric pressure, temperature, and relative humidity.

All measurements are based on Vaisala technology, including the PTU module for barometric pressure, temperature, and humidity; the WINDCAP sensor for wind speed and direction; and the RAINCAP sensor for rainfall, rain intensity, and duration.

The precipitation measurement detects the impact of individual rain drops, which is proportional to the volume of the drops. The signal from each drop is converted directly to the accumulated rainfall.



Figure 1: Vaisala WXT520 multi-parameter weather sensor

Connecting to an iSIC Data Logger

Vaisala weather transmitters are manufactured with or without heating capabilities for the wind and rain sensors. This optional feature includes an automatic control circuit that switches on only at low temperatures.

In order to connect the sensor properly, the user must be conscious about which type of sensor (heated or non-heated) is being connected to the data logger.

NexSens manufactures MS8 to flying lead cables to accommodate quick and easy connections to SDI-12 sensors with terminal strip wiring configurations such as the Vaisala WXT520.



Figure 2: NexSens A58 MS8 to flying lead cable, used for wiring sensors for plug and play connections to iSIC data loggers

When purchased together, the weather transmitter will arrive prewired for a plug and play connection to the iSIC data logger. The MS8 port on the iSIC enclosure (see Figure 3) provides a pluggable connection that accommodates the male MS8 connector on A58 interface cables.

CONNECTING TO AN ISIC DATA LOGGER

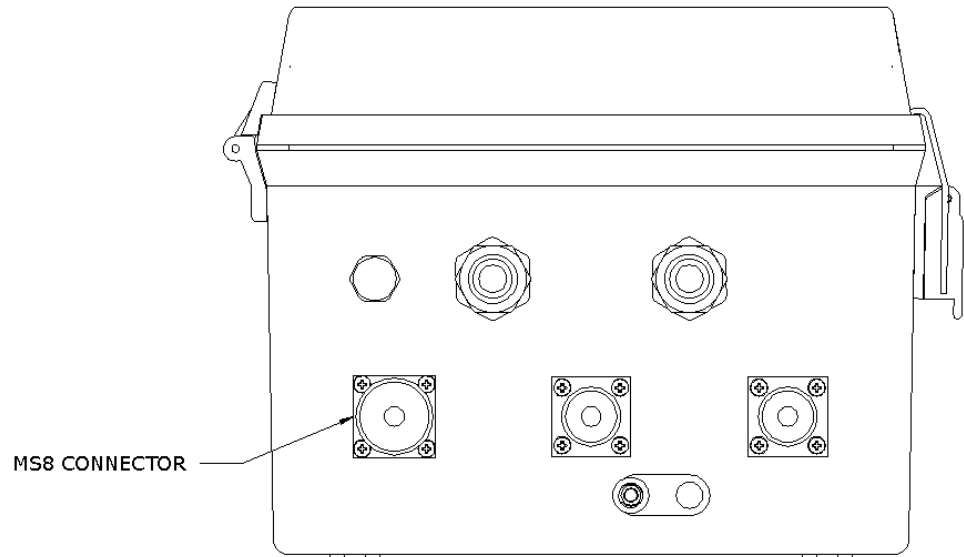

Figure 3: iSIC data logger enclosure (bottom view)

Additionally, weather transmitters can be wired directly to the iSIC terminal strips within the enclosure. To wire a WXT520 into the iSIC, route the cable and wires through a gland fitting installed in the enclosure, and then unplug the green terminal strip from the data logger before securing individual wires according to the wiring diagram below. Avoid clamping on wire insulation.



Figure 4: Unplug the green terminal strip from the data logger before wiring the sensor

CONNECTING TO AN ISIC DATA LOGGER

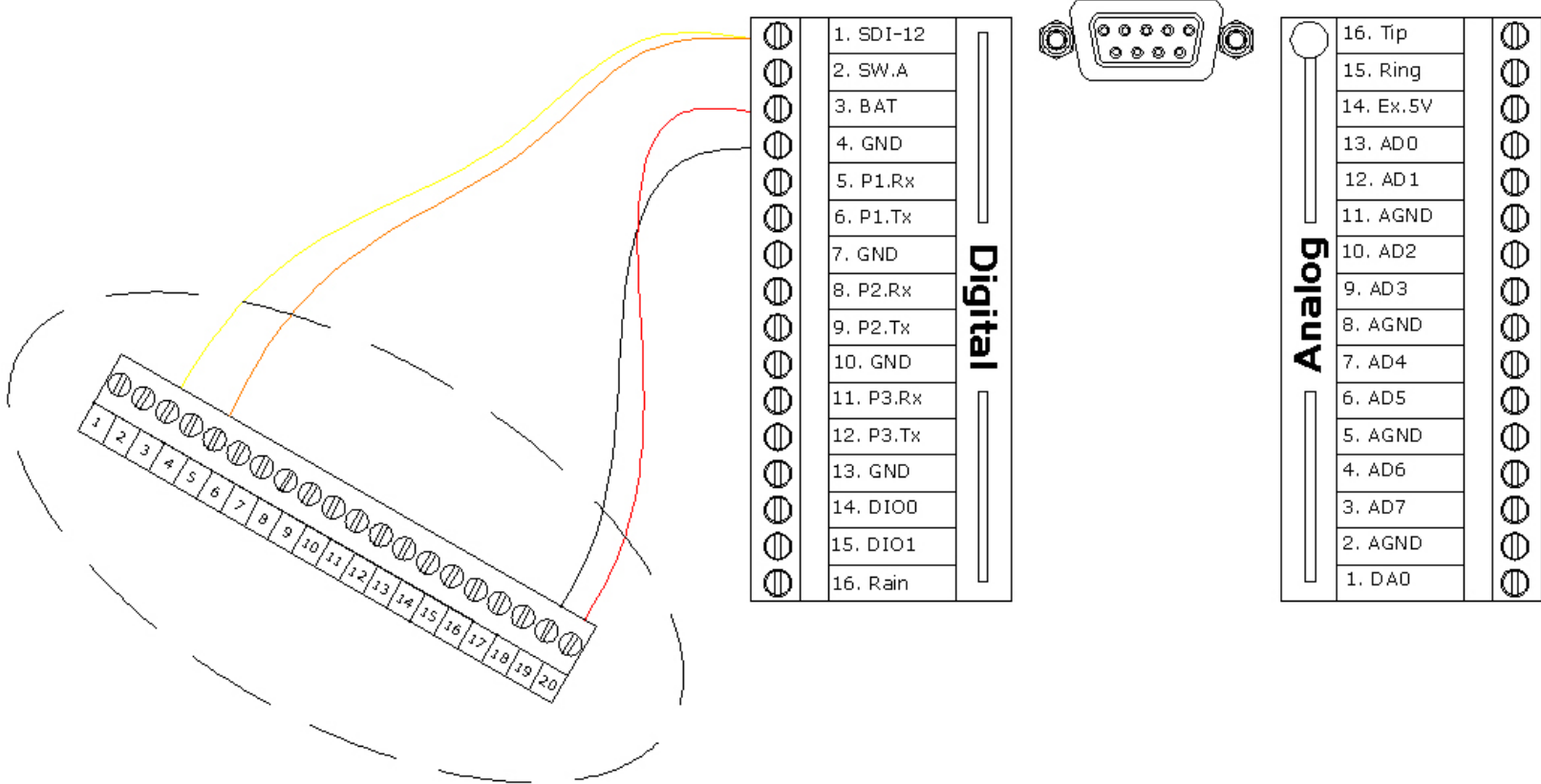

Figure 5: Physical wiring of non-heated WXT520 multi-parameter weather sensor with internal Vaisala sensor terminal strip shown

CONNECTING TO AN ISIC DATA LOGGER

Table 1: Table for wiring a non-heated Vaisala WXT520 to an iSIC data logger via SDI-12

Digital		Analog	
1. SDI-12	Orange (TX-) Yellow (RXD)	16. Tip	-
2. SW.A	-	15. Ring	-
3. BAT	Red (VIN+)	14. Ex.5V	-
4. GND	Black (VIN-)	13. AD0	-
5. P1.Rx	-	12. AD1	-
6. P1.Tx	-	11. AGND	-
7. GND	-	10. AD2	-
8. P2.Rx	-	9. AD3	-
9. P2.Tx	-	8. AGND	-
10. GND	-	7. AD4	-
11. P3.Rx	-	6. AD5	-
12. P3.Tx	-	5. AGND	-
13. GND	-	4. AD6	-
14. DIO0	-	3. AD7	-
15. DIO1	-	2. AGND	-
16. Rain	-	1. DA0	-

Notes:

- The WXT520 must be wired to pin BAT for consistent averaging and data collection. Switch power should not be used.

If the heated version of the WXT520 weather transmitter is used, external power must be wired to the terminal strip inside of the weather sensor. Vaisala recommends using a second source to supply power to the heating element.

CONNECTING TO AN ISIC DATA LOGGER

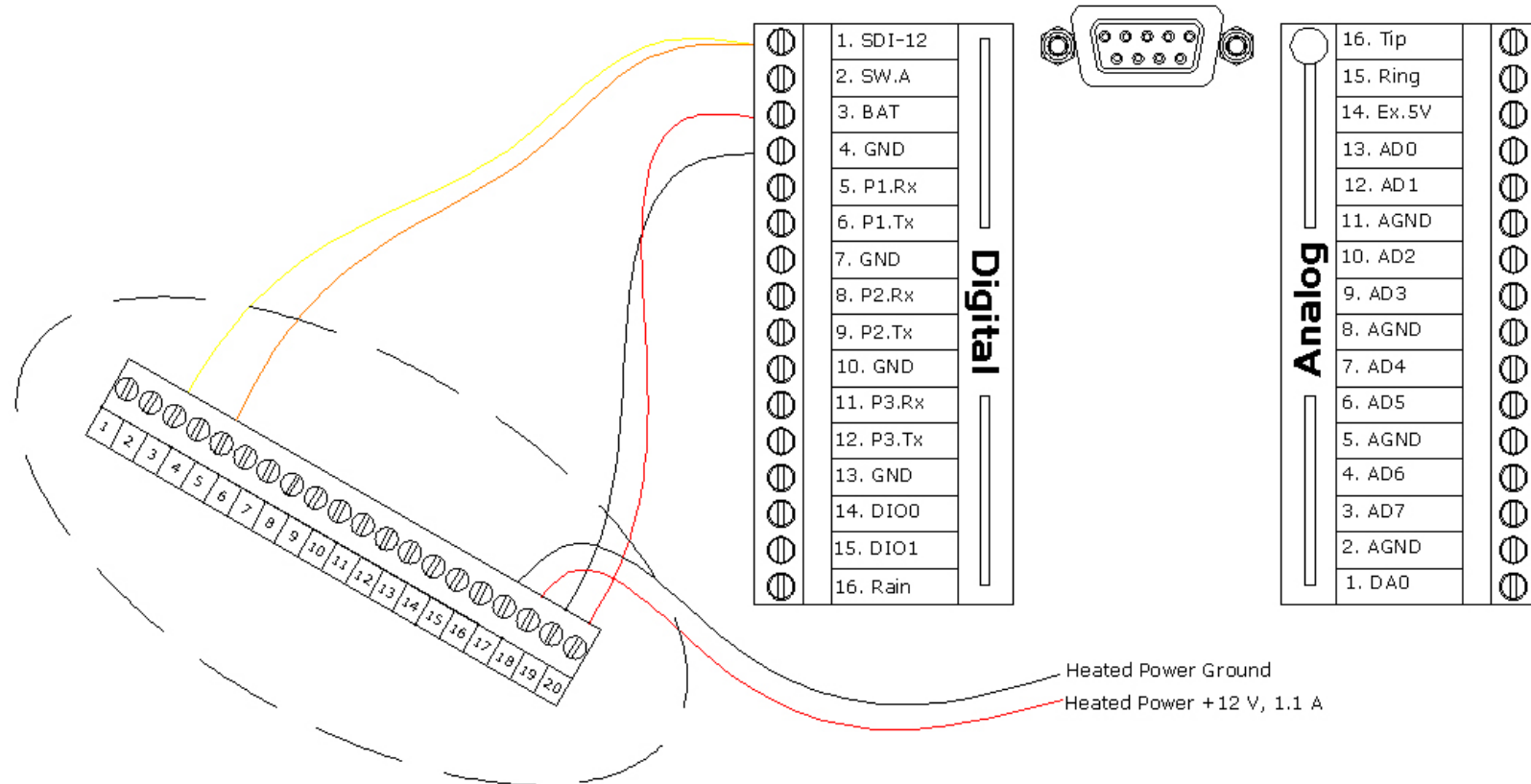

Figure 6: Physical wiring of heated WXT520 multi-parameter weather sensor with internal Vaisala sensor terminal strip shown

However, power can be drawn directly from the data logger to power the heating element if sufficient battery capacity and charging capabilities are available for the system. To accomplish this, the heating element can be wired to Pin 3. BAT and Pin 4. GND.

Installation

During installation the weather station must be mounted vertically and aligned to the north for best measurements. Adhere to the following mounting and alignment recommendations to ensure quality data.

Mounting Weather Sensor

The Vaisala WXT520 can be mounted either vertically atop a 2" NPT male pipe thread or horizontally on a horizontal mounting arm.

The NexSens WXT510-M PVC mounting adapter is used to mount the weather sensor on a 2" NPT pipe. It simply threads on, providing a custom mount arm designed to accommodate WXT520 mounting kit adapters. The accessory can also be used with preconfigured iSIC data logger MAST systems (see typical deployment solution shown below), as they both utilize 2" NPT threads.



Figure 7: WXT510-M weather sensor mount with 2" NPT pipe thread and custom mount arm (left) and typical deployment solution (right)

The NexSens M-ARM-E horizontal mounting arm allows for installation onto any vertical pipe less than 2 3/8" in

diameter. It consists of a 3' section of aluminum unistrut, 1" EMT pipe to accommodate WXT520 mounting kit adapters, and a u-bolt for quick attachment to any a preinstalled pole.



Figure 8: NexSens M-ARM-E mounting arm for Vaisala WXT520 weather transmitters

Alternatively, the M-ARM-D dual sensor mounting arm is designed to accommodate either a LI-COR PAR or solar radiation sensor along with a Vaisala WXT520. However, it functions exactly the same as the M-ARM-E for weather station mounting.

Wind Direction Alignment

For ease of use it is recommended that the WXT520 face due north. To aid in aligning the wind direction transducers properly, an arrow and the text "North" are displayed on the bottom of the transmitter's housing. The arrow should point due north.

To align Weather Transmitter WXT510, proceed as follows:

1. Make sure the sensor is free to rotate on the mounting (i.e. the set screw on the mounting kit adapter is loose)
2. Use a compass to align the arrow on the sensor to the north. If the arrow is unable to point due north, measure and record the deviation angle from 0° (see figure below). This is required if data is intermediately processed within the WXT520 before being reported to the iSIC or SDL data logger.

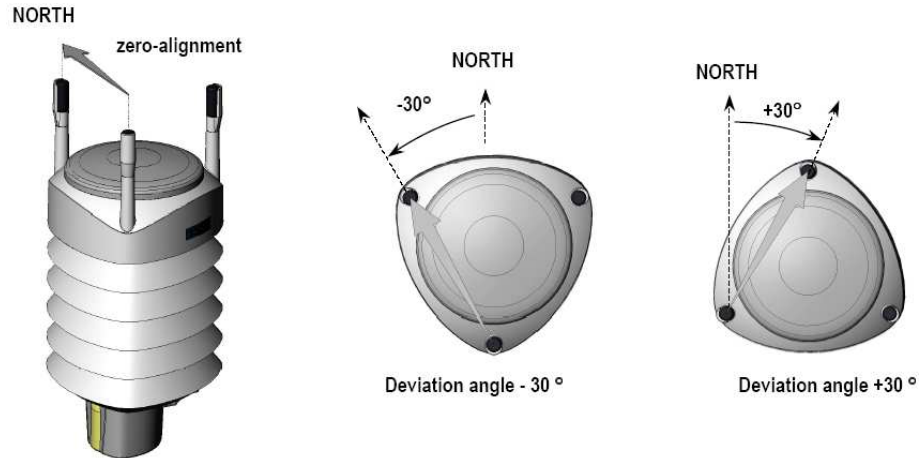

Figure 9: WXT520 weather transmitter north arrow displayed with corresponding positive and negative deviation angles

3. Tighten the set screw on the mounting kit adapter.
Mounting and alignment is now complete.

Computer Interface

iChart software is used to set up the iSIC data logger, as well as to acquire and process data. Launch the software and select **File | New Project**. Follow the Setup Device Wizard to create a project file. Additional information is available in the iChart manual.



1415 Research Park Drive
Beavercreek, OH 45432
937-426-2703
www.NexSens.com