

In-Situ Aqua TROLL

Aqua TROLL 100
Aqua TROLL 200

Sensor Interface Manual



Table of Contents

Overview	1
Installation	2
Connecting to an iSIC Data Logger	2
Computer Interface	4

Revision: 02

Revision Code: 20A10

Overview

The In-Situ Aqua TROLL 100 is a conductivity and temperature logger and the Aqua TROLL 200 simultaneously measures temperature, conductivity, and water level. Both instruments are factory-calibrated and validated with NIST-traceable standards. Both models feature a durable titanium housing to resist fouling and safeguard against corrosion.

The Aqua TROLL 100 was designed for conductivity measurements. These instruments are typically used to characterize water quality changes relative to a baseline or to estimate the concentration of contaminants.

The Aqua TROLL 200 dynamically compensates level readings for changes in water density due to changes in salinity.



Figure 1: In-Situ Aqua TROLL 100 (Right) and Aqua TROLL 200 (Left)

Installation

The In-Situ Aqua TROLL 100 and Aqua TROLL 200 can be installed in 1 inch or larger deployment pipes. The units can also easily be mooring deployed under NexSens data buoys.

Additionally, for best level measurements make sure the Aqua TROLL 200 is installed below the lowest anticipated water level during unattended deployments.

For vented sensors, care should be taken to keep the cable jacket from bending tighter than a one inch radius. This can pinch the vent tube, thus preventing an accurate vented level reading.

Connecting to an iSIC Data Logger

To wire the sensor into the iSIC, route the cable and wires through a gland fitting installed in the enclosure, and then unplug the green terminal strip from the data logger before securing individual wires according to the wiring diagram below. Avoid clamping on wire insulation.

NOTE

An In-Situ twist-lock to flying lead adapter cable is required for wiring Aqua TROLL instruments directly to the iSIC data logger.



Figure 2: Unplug the green terminal strip from the data logger before wiring the sensor

For connecting two TROLL instruments to the same data logger, use the same pins on the iSIC terminal strip. However, attaching more than two instruments to the same terminals may be cumbersome. Consider a junction box for signal splitting if this is the case.

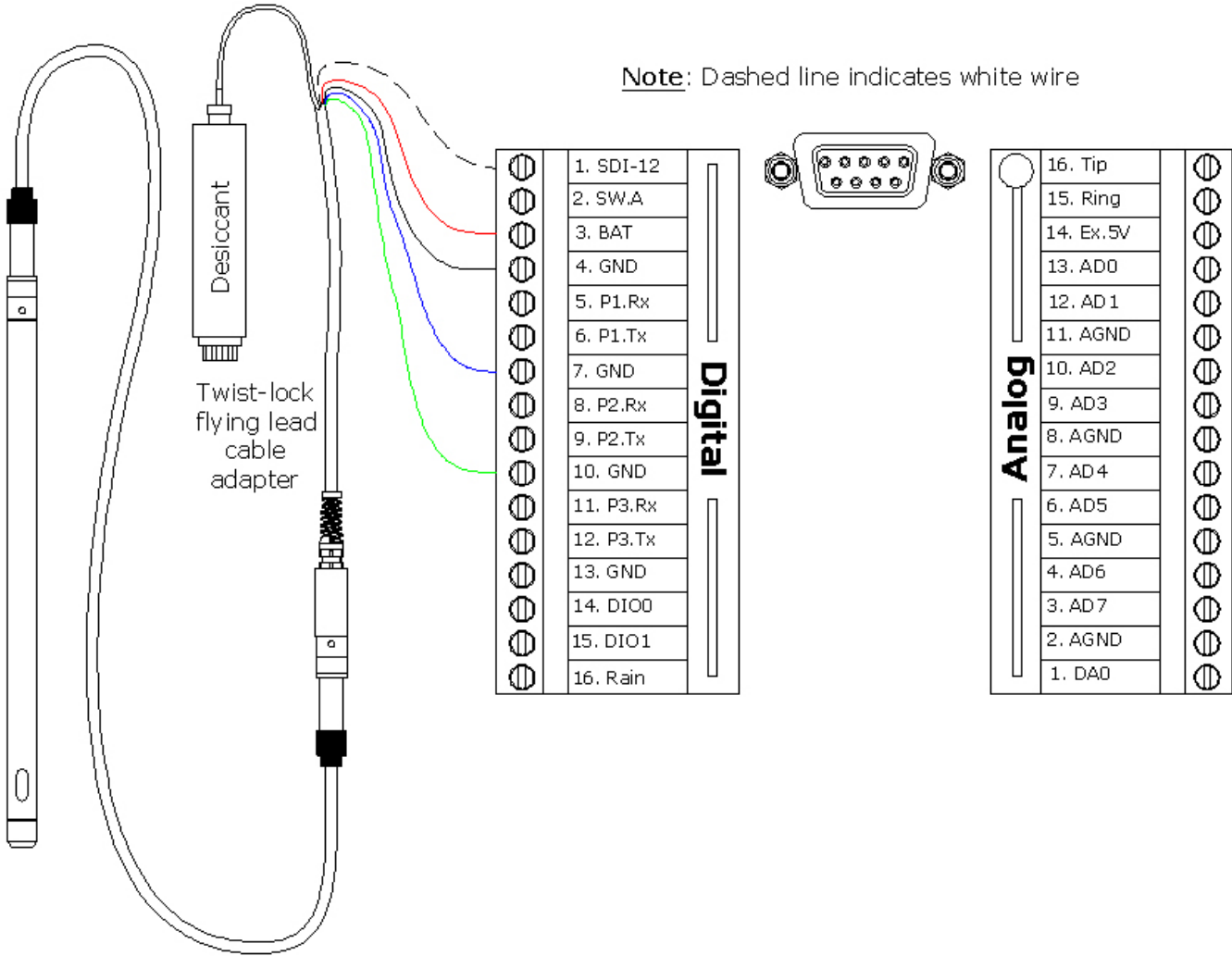

Figure 3: Physical wiring of an In-Situ Aqua TROLL to an iSIC data logger

Table 1: Table for wiring an In-Situ Aqua TROLL to an iSIC data logger

Digital		Analog	
1. SDI-12	White (SDI-12)	16. Tip	-
2. SW.A	-	15. Ring	-
3. BAT	Red (EXT PWR)	14. Ex.5V	-
4. GND	Black (GND/RETURN)	13. AD0	-
5. P1.Rx	-	12. AD1	-
6. P1.Tx	-	11. AGND	-
7. GND	Blue (RS-485 +)	10. AD2	-
8. P2.Rx	-	9. AD3	-
9. P2.Tx	-	8. AGND	-
10. GND	Green (RS-485 -)	7. AD4	-
11. P3.Rx	-	6. AD5	-
12. P3.Tx	-	5. AGND	-
13. GND	-	4. AD6	-
14. DIO0	-	3. AD7	-
15. DIO1	-	2. AGND	-
16. Rain	-	1. DA0	-

Notes:

- The vented Aqua TROLL 200 is recommended for use with iSIC data loggers.

Computer Interface

iChart software is used to set up the iSIC data logger, as well as to acquire and process data. Launch the software and select **File | New Project**. Follow the Setup Device Wizard to create a project file. Additional information is available in the iChart manual.



1415 Research Park Drive
Beavercreek, OH 45432
937-426-2703
www.NexSens.com